

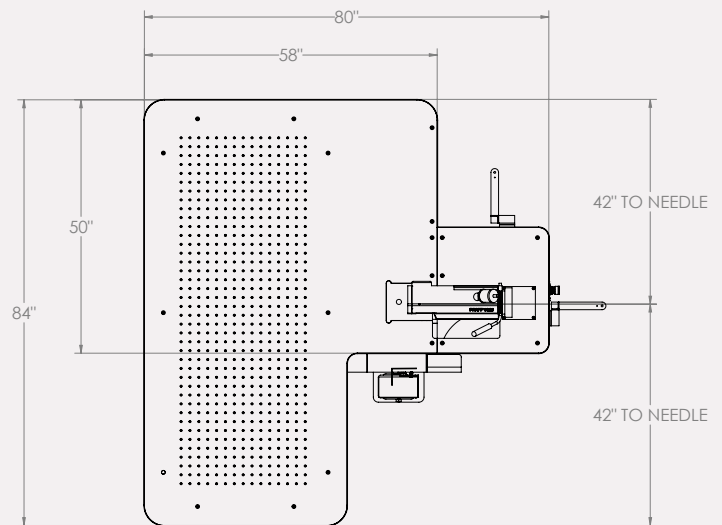

Ultra HCB Ergo *Half-Capper Binding Machine*

This heavy-duty binding machine is designed to join the thickest borders to quilt panels or non-woven decking materials. Ergonomic features such as a strong Pfaff sewing head, integrated air table, and adjustable-height legs require less effort for any operator to produce top-quality products.



A powerful air table makes it easy to turn heavy goods throughout the binding process. The working surface can be electronically raised or lowered 12" (30.5 cm) to fit the personal comfort of any employee at the touch of a button.

SPECIFICATIONS	ULTRA HCB ERGO
Max sewing speed-rpm	3200
Recommended sewing speed-rpm	3000
Max thickness	2-1/2"
Minimum thickness	Flat
Stitches per inch (spi)	4-5
Presser foot height	1/2"
Binder size	1-1/4" tape with 3/8" opening standard (special sizes and styles available)
Needle type	135X17
Needle size	22-24
Voltage/phase	220/1
Current (amps)	15
Air pressure (psi)	80
Air consumption (cfm)	0.1
Production (units/minute, hr, or shift)	1/min

GSG ergonomic systems provide a healthier, more productive process – a vital feature in today's challenging labor environment where employers are finding it hard to attain qualified workers and retain good employees.

- High-volume air table
- Adjustable tabletop height range of 12" (30 cm) for ergonomically comfortable operations
- Stainless-steel trough to better manage border material fed into the sewing area
- Joins thick, quilted borders to either quilt panels or flat, non-woven goods
- Stout Pfaff sewing head for easily processing thick materials

Global Systems Group® (GSG) is a collection of the world's leading mattress machinery companies. These GSG machinery companies represent leading-edge technology in computerized quilting machines and panel cutters, automated and conventional sewing machines, material handling solutions, and mattress-packaging equipment.

800-343-8138 • 417-237-6254 • GSGcompanies.com



131 Zapletal Way
Carthage, MO 64836 USA