

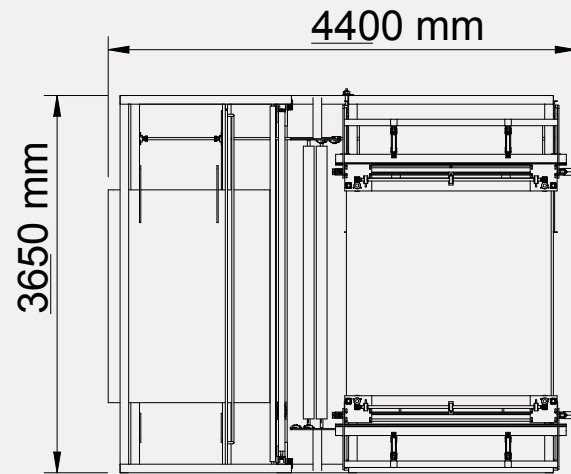

ME103

Compact, Two-Stage Wrapper

Wrapping machine from Merello Ingenieros is a value-priced, compact machine designed for light-volume producers.



The ME103 is a compact, auto-package machine that offers the same great packaging quality as the popular ME104.

- Utilizes same Cold Seal technology of popular Merello ME104 and ME105 wrappers.
- Cold Seal technology reduces faulty seals caused by prematurely melted film during heat cycle.
- Top-quality packaging for low-volume producers.
- PLC controls.
- Manually adjustable for various sizes.
- Teflon heat strips are easily changed in five minutes and can last 100,000+ cycles (depending on production variables).
- One cycle per minute.
- Wrap units 170 x 70 x 10 cm to 220 x 160 x 35 cm.
- CE-compliant.
- Absence of top-seal bar wiring eliminates electric malfunctions due to wiring wear from cycle repetitions.

Global Systems Group® (GSG) is a collection of the world's leading mattress machinery companies. These GSG machinery companies represent leading-edge technology in computerized quilting machines and panel cutters, automated and conventional sewing machines, material handling solutions, and mattress-packaging equipment.

800-343-8138 • 417-237-6254 • GSGcompanies.com



A DIVISION OF LEGGETT & PLATT

131 Zapletal Way
Carthage, MO 64836 USA